

READYGo™ FVP

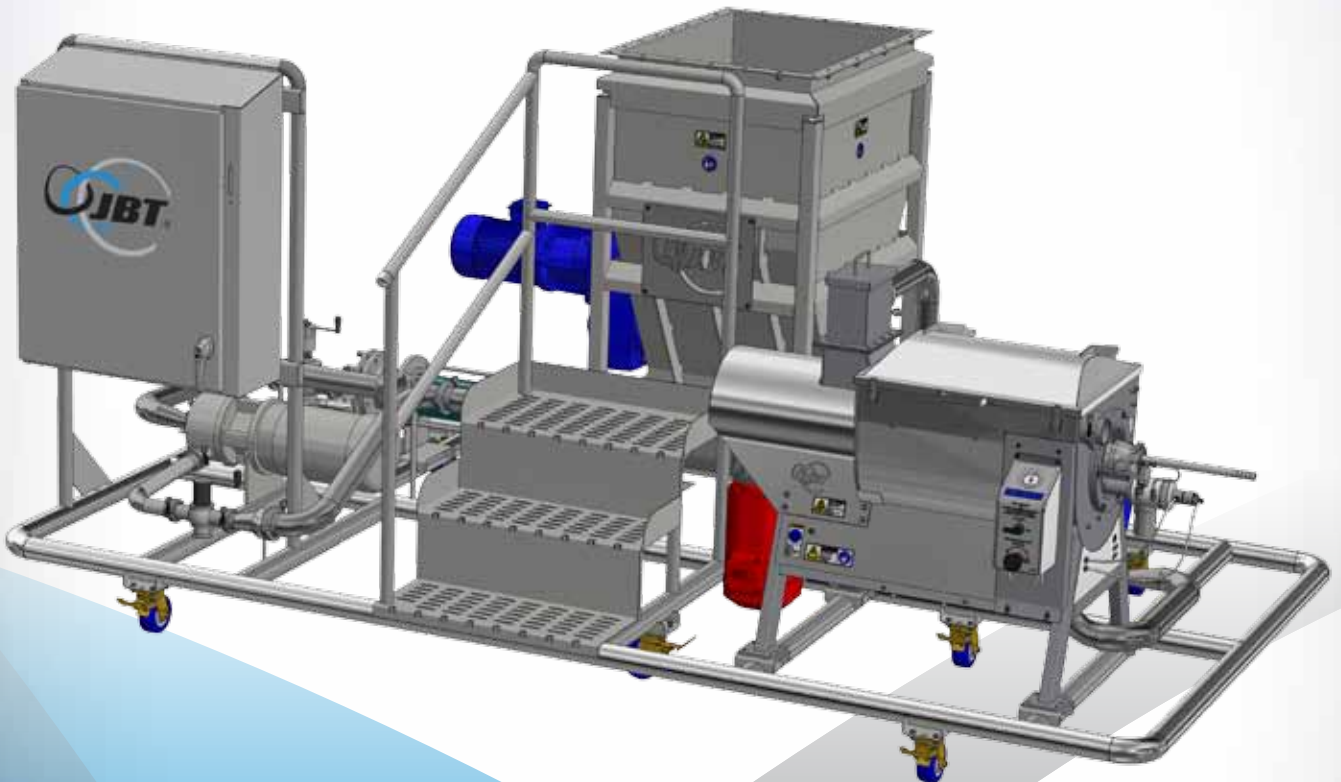

Fruit and Vegetable Processing skid system
for making cold-extracted juices

READYGo™ FVP

JBT's READYGo FVP (Fruit and Vegetable Processing) skid is a process system for making cold-extracted juices from a variety of fruits and vegetables.

Description

The skid is self-contained and mounted on casters so it can be moved easily. It incorporates JBT's proven chopper pump, the FVX-5, with an external flow-through grinder and a UCF110 screw finisher. The FVX-5 performs the initial size reduction and can process whole fruits and vegetables ranging in size from whole watermelons to carrots, beets, celery, leafy vegetables and berries. Depending on the desired product, the optional FVG grinding system can further reduce the size of the chopped product in preparation for juice extraction from the UCF110 finisher. JBT's ReadyGo FVP skid can be the heart of your juice production process to make a variety of natural juice drinks and blends.

Overview

Juice production involves three major operations: 1) Initial size reduction; 2) Optional secondary size reduction; and, 3) Finishing. JBT has developed a new modular skid-mounted system providing a continuous and hygienic process capable of processing up to 5 metric tons per hour of raw product generating 5 to 20 GPM of juice. No heat is applied during extraction making it suitable for immediate bottling followed by HPP processing with JBT's avure high-pressure processing systems.

Features

- Continuous processing of fruit and vegetables
- Hygienically designed to be easily cleanable
- Capable of Clean-in-Place with appropriate CIP system
- All stainless and food grade polymer food-contact surfaces
- Optional control panel with variable frequency drives for speed control for ease of electrical installation
- Integrated hygienic product pump to pump juice to downstream processes
- Mounted on casters for easy movement
- Can be configured to use JBT's FTE turbo extractor for production of viscous juices and purees for smoothies

JBT's process uses three major pieces of equipment: 1) FVX-5; 2) FVG grinder; and, 3) UCF110 finisher. These three machines can generally be offered for the majority of fruit and vegetable puree/juice requirements.

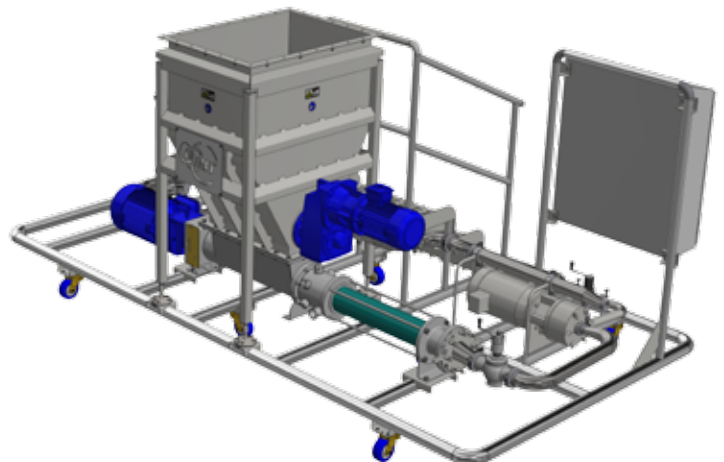

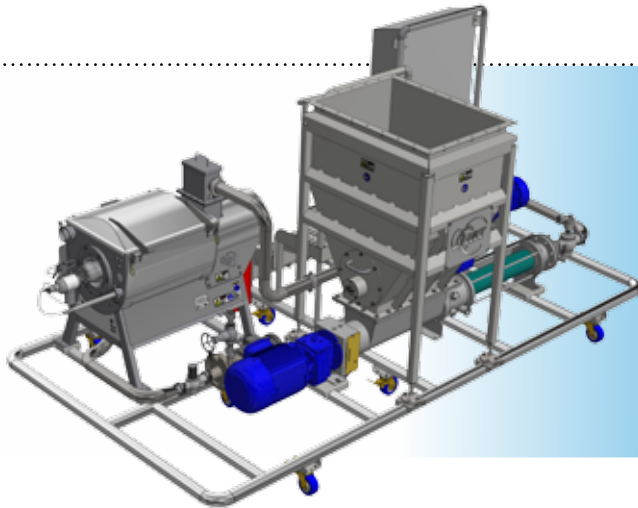

APPROXIMATE YIELD ON COMMON PRODUCTS	
Carrot	Up to 62%
Beets	Up to 65%
Melons	75-80%
Kale	50-60%
Lettuce	90%
Cucumber	92%

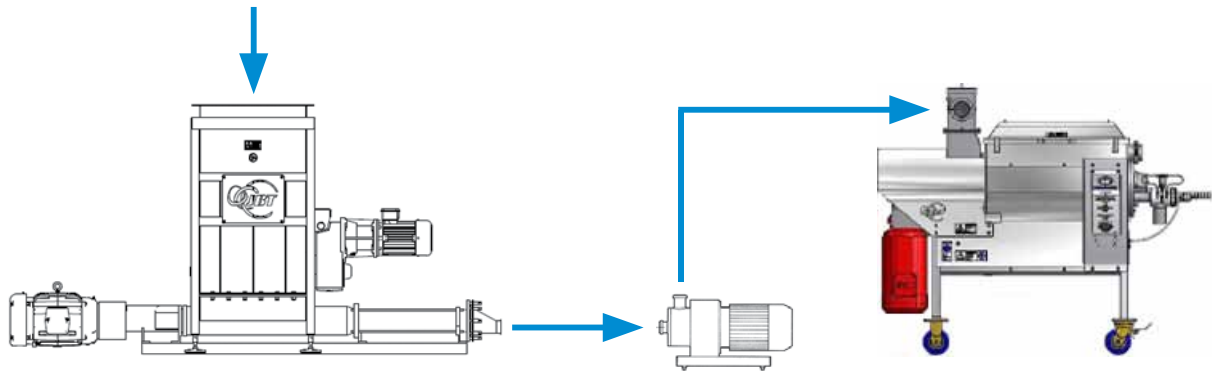

FVX-5 - Coarse chop and pump

FVG - Size reduction

UCF110 Juice Finisher
 2-15 CPS viscosity
 5%-20% suspended solids

Competitive Benefits

There are a number of competitive advantages to JBT's READYGo FVP skid-mounted system, especially against bag presses.

READYGo FVP	Bag Press
Continuous operation	Batch feed (Bag press)
Easily cleaned, CIP able	Hard to clean
Enclosed juice system	Open to atmosphere, contamination possible
Easily automated	Difficult to automate
Up to 5 TPH capacity	2 to 4 TPH depending on press
Hygienic design principles	Bags not hygienic, must be removed and washed
Juice and puree, optimize quality parameters, viscosity, solids	Juice only

Approximate Specifications

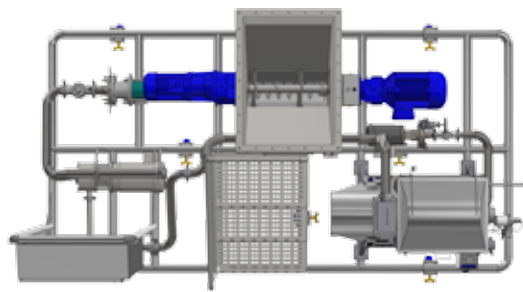
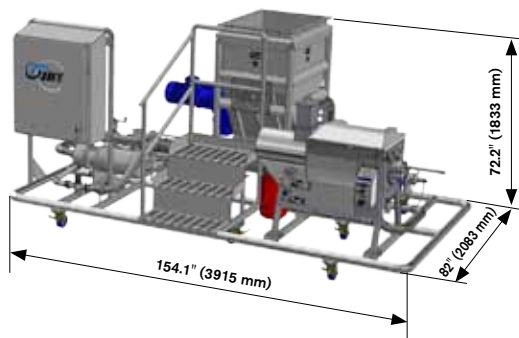

ADDITIONAL EQUIPMENT AND SERVICES CAN BE OFFERED TO SUPPLY A COMPLETE PROCESS SYSTEM INCLUDING:

Automation and controls	Bottle filling system
CIP system	Blending system
Deaerator	Piping and installation
HPP system	Commissioning and startup

COUNT ON JBT TO HELP PROTECT YOUR INVESTMENT

JBT's greatest value in PRoCARE® services comes from preventing unexpected costs through smart, purposeful, and timely maintenance based on unmatched knowledge and expertise. PRoCARE service packages are offered as a maintenance agreement in various service levels, depending on your production and cost management requirements.



JBT LIQUID FOODS

FRESH PRODUCE TECHNOLOGIES | FRESH-CUT, ROBOTICS, STEAMING TO PRODUCT LINE MIX | FRUIT AND VEGETABLE PROCESSING | SECONDARY PROCESSING | ASEPTIC SYSTEMS | FILLING AND CLOSING | IN-CONTAINER STERILIZING | HIGH-PRESSURE PROCESSING | POWDER PROCESSING | TUNA PROCESSING

OUR BRANDS



ALSO REPRESENTING



Europe

John Bean Technologies SpA
Via Mantova 63/A
43122 Parma
Italy
Phone: +39 0521 908 411
Fax: +39 0521 460 897

John Bean Technologies NV
Breedstraat 3
9100 Sint-Niklaas
Belgium
Phone: +32 3 780 1211
Fax: +32 3 777 7955

John Bean Technologies Spain, S.L.U.
Autovia A-2, km 34,400
28805 Alcalá de Henares
Madrid, Spain
Phone: +34 91 304 0045
Fax: +34 91 327 5003

Latin America

JBT de México S de RL de CV
Camino Real a San Andrés Cholula No. 2612
Col. San Bernardino Tlaxcalancingo
72820 San Andrés Cholula, Puebla
México
Phone: +52 222 329 4902
Fax: +52 222 329 4903

North America

John Bean Technologies Corporation
400 Fairway Avenue
Lakeland, FL 33801
USA
Phone: +1 863 683 5411
Fax: +1 863 680 3672

John Bean Technologies Corporation
2300 Industrial Avenue
Madera CA 93639
USA
Phone: +1 559 661 3200
Fax: +1 559 661 3156

South America

John Bean Technologies Máq.
e Equip. Ind. Ltda.
Av. Eng Camilo Dinucci 4605
14808-900 Araraquara, São Paulo
Brazil
Phone: +55 16 3301 2000
Fax: +55 16 3301 2144

Asia Pacific

John Bean Technologies (Shanghai) Co., Ltd.
Room 1908, Hongwell International Plaza,
1600 West Zhongshan Road,
Xuhui District, Shanghai 200235,
PRC
Phone: +86 21 3339 1588
Fax: +86 21 3339 1599

John Bean Technologies (Thailand) Ltd.
No. 159/26 Serm-Mit Tower
Room no. 1602-3 Sukhumvit 21 Road
Klongtoey Nua Sub-district, Wattana District
Bangkok 10110 Thailand
Phone: +66 2 257 4000
Fax: +66 2 261 4099

South Africa

John Bean Technologies (Pty) Ltd.
Koper Street
Brackenfell
Cape Town, South Africa 7560
Phone: +27 21 982 1130
Fax: +27 21 982 1136

We're with you, right down the line.™

hello@jbt.com | jbt.com/foodtech

